

APPLICATION UPGRADE MODES

FOR WEISSCAM HS-2 MKII CAMERAS

Overview

The HS-2MKII Application Upgrade Modes cover a variety of modules to enhance the operation with the WEISSCAM HS-2 in different applications: Film Mode, Rental Mode, and Studio Mode.



The **Film Mode** is an "All Purpose" Camera Module with enhanced Image quality for recordings especially in 24p/25p/30p and lower speed rates.



The **Rental Mode** is scalable features for the camera rent-out and especially designed for rental companies. The camera rental can offer the WEISSCAM HS-2 to a wider range of application using a cost structure tailored to the needs of his customers and rent out the camera more often.



The **Studio Mode** offers RAW support for recordings on PC especially in a studio environment, without not possible. The WEISSCAM HS-2 camera body can be installed as part of a studio equipment and be connected to the existing infrastructure while use RAW and HD-SDI recording options.

Availability

The Application Upgrade Modes are available through P+S TECHNIK or its special reseller from March 2011.

Specifications

Subject to technical change without prior notice

	Film Mode	Studio Mode	Rental Mode		
Feature Sets	-	-	Commercial	Fiction	TV Drama
Enhanced Image Quality	x				
More rental possibilities			x	x	x
Feature sets			x	x	x
RAW recording on PC		x			
Feature Set Management (rental / onset)			x	x	x
Film Mode Control	x		(x)*	(x)*	
Studio Mode Control		x			
3D Sync Mode	x				
Resolution max.	2K	2K	2K	2K	1080
RAW Workflow	DM-2	PC	DM-2	DM-2	-
HD Workflow	DM-2 / HD Recorder	(DM-2) / HD Recorder	DM-2 / HD Recorder	DM-2 / HD Recorder	DM-2 / HD Recorder
Recording Speed** max.	1 - 2.200 fps	1 - 4.400 fps	1 - 4.400 fps	23 - 500 fps	23 - 120 fps
Output Formats	?			2, 4, 8, 15, 16, 32, 40 disabled	2, 4, 8, 15, 16, 32, 40 disabled

* if in addition to the Rental Mode the Film Mode is installed and unlocked for the Hand Unit

** depending on resolution - see camera specs for more information

Installation

Together with your order you have send the serial number of your HU-2 Hand Unit to P+S TECHNIK. We will send you the software upgrade per Email and you only have to put on your HU-2 Hand Unit per USB-Stick and release the software.

Film Mode

Key Features

- Wider scope of application for quality sensitive film production
- Enhanced image Quality especially in 24p/25p/30p and lower high speed rates
- Increased dynamic range and 30% higher signal performance

HS-2 Film Mode is an "All Purpose" Camera Module with enhanced Image quality for recordings especially in 24p/25p/30p and lower speed rates. It allows using the camera for different purposes such as fiction, commercial, documentary and TV Drama.

The HS-2 with Film mode offers to record images with increased dynamic range and a 30% better performance on the signal. Image quality is received at the expense of tolerable half of the usual frame rate i.e. max.1065fps @ 1080p or 2200 fps @ 720p.

Technical Specs

- Film Mode Control active
- Dark Reference Control active (if Film Mode is disabled)
- Sync Modes enabled
- Max. 1065 fps @ 1080p
- Max. 2200 fps @ 720p

Rental Mode

Key Features

- Scalable features for scalable rental day rates
- Feature sets for commercial, fiction and TV drama
- Feature sets can be changed and unlocked on set by entering a PIN-Code

The Rental Mode is a scalable feature for the camera rent-out to use the HS-2 as an "all-purpose" camera. So it is especially important for rental companies. It supports rental companies to enhance their camera usage for different applications. It provides scalable rent-out features made for different cases of use in shooting commercials, fiction, TV Drama or other applications. It should support to rent out the HS-2 for different daily or weekly charges depending on the production. It is possible to release different features for different production types and aspects such as

- Maximum Frame rate
- Film Mode
- Studio mode

Therefore a rental company is capable to offer different charges per application to clients.

Studio Mode

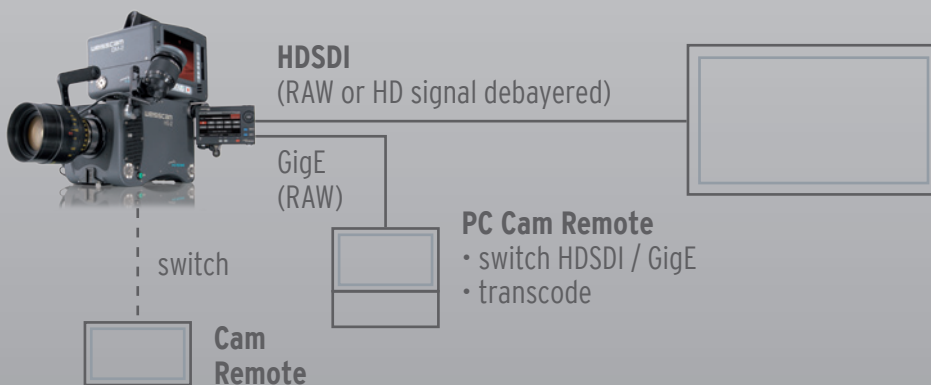

Key Features

- RAW recording to PC/Server
- Camera configuration adjustment via Hand Unit HU-2 (Camera (fps, Format), Looks, etc.)
- HD Preview possibility via HDSDI (on Monitor)
- HD Recording possibility via HDSDI (on external HD-SDI recorder)

The Studio Mode provides RAW support for recordings on PC without additional devices needed, which is especially interesting in Studio environment.

The complete camera configuration including debayer settings for preview and recording is done via the Hand Unit HU-2. During recording and playback from the camera RAM HD-SDI preview is available. For download of the recorded data to the PC the output is switch from HD-SDI to GigE via the Hand Unit HU-2.

Technical Specs

Feature Set - Commercial

- The Film Mode can be activated and deactivated if Film Mode is released
- The Studio Mode can not be activated
- Dark reference can not be activated when the Film Mode is activ
- Sync Modes can not be activated
- Recordingspeeds can be set without any restrictions

Feature Set - Fiction

- The CI Mode can be activated and deactivated
- The Studio Mode can not be activated
- Dark reference can be chosen
- The Sync Modes can not be activated
- FPS can be chosen in a range from 23 to 500
- Output formats 2, 4, 8, 15, 16, 32, 40 disabled

Feature Set - TV Drama

- The CI Mode can not be activated
- The Studio Mode can not be activated
- Dark reference can not be chosen
- The Sync Modes can not be activated
- FPS can be chosen in a range from 23 to 120
- Output formats 2, 4, 8, 15, 16, 32, 40 disabled

Technical Specs

- The Studio Mode can be activated and deactivated
- Dark Reference can be activated and deactivated
- Recordingspeeds can be set without any restrictions